

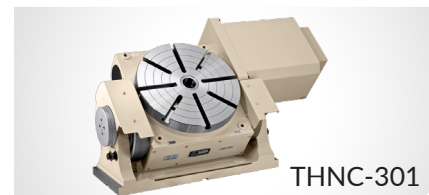





THNC-251, 301

ROTARY/TILT TABLE WITH MANUAL TILT

The THNC-Series tables have a NC controlled rotary axis and a manual tilt axis. The highly rigid body incorporates a powerful hydraulic clamp mechanism.

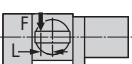

THNC-301

Table Model		THNC-251		THNC-301	
Tilt Range		0° ~ +93°			
Table diameter	mm	250		320	
Table height at 0° position	mm	230		265	
Center height at 90° position	mm	210		235	
Center bore	Nose Diameter	mm	40H7		40H7
	Thru Diameter	mm	32		40
Table T-slot width		12H7		14H7	
Guide block width		18h7		18h7	
Servo motor (Fanuc)*		<i>Rotary</i>	<i>Tilt</i>	<i>Rotary</i>	<i>Tilt</i>
		Alpha 4i	Manual	Alpha 8i	Manual
Maximum motor speed	rpm	5,000	-	4,000	-
Speed reduction ratio		1/180	-	1/180	-
Maximum table speed	rpm	33.3	-	22.2	-
Inertia converted into motor shaft	x 10 ⁻³ kg·m ²	.24	-	.34	-
Clamp system		Hydraulic** @500psi	Manual @19.6 Nm (14.4 ft.lbs.)	Hydraulic** @500psi	Manual @35.3 Nm (26 ft.lbs.)
Clamp torque	Nm (ft. lbs.)	490 (361)	490 (361)	833 (614)	1,862 (1,372)
Indexing accuracy	arc sec.	±7.5	±30	±7.5	±30
Net Weight	kg (lbs.)	125 (275)		180 (396)	
Allowable wheel torque - rotary	Nm (ft. lbs.)	470 (346)		764 (563)	
Allowable work inertia	kg·m ²	.62		2.25	
Allowable work weight	0° tilt angle		kg (lbs)	80 (176)	200 (440)
	0° ~ 90° tilt angle		kg (lbs)	40 (88)	100 (220)
Allowable load when table clamped			N (lbf)	6,860 (1,537)	9,800 (2,195)
			Nm (ft. lbs.)	490 (361)	833 (614)
			Nm (ft. lbs.)	490 (361)	1,862 (1,372)

* Other motors & RPM available

** Booster optional

Specifications subject to change without notice

Dimensions

Drawings not to scale • Dimensions = mm

THNC-251

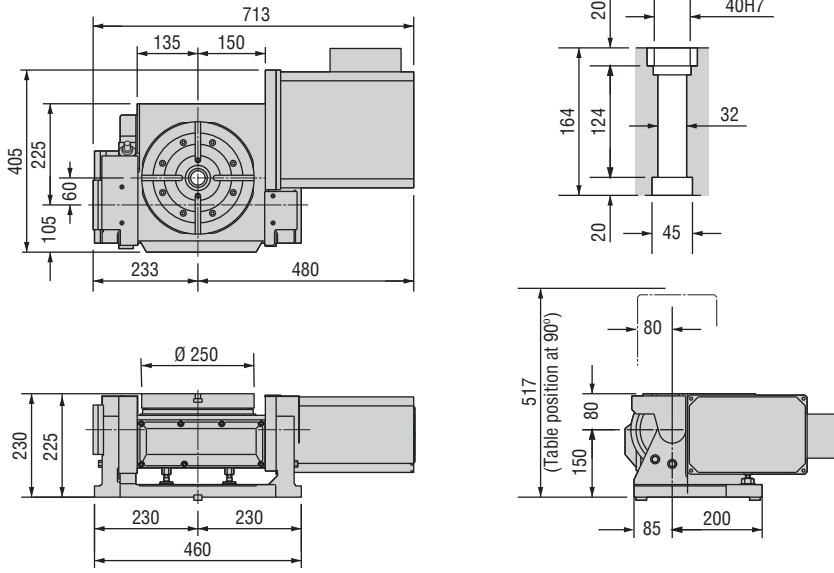

OPTIONAL TPC5 SERIES NC Controller



THNC-301

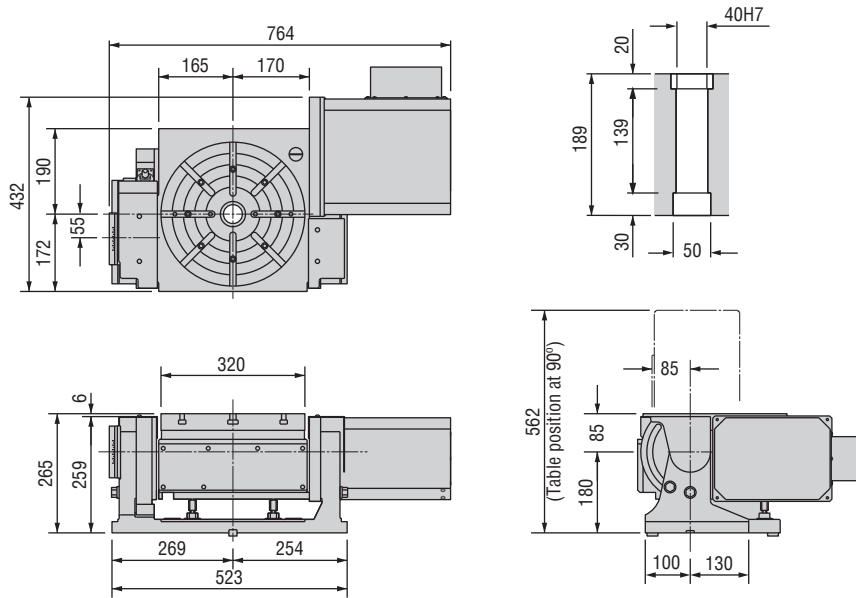

Options & Accessories

TPC NC Controller	p.62
Chucks	p.74
Tailstock	p.75
Support Spindle	p.77
Face Plate	p.77
Encoder / Scale	p.78
Pull Stud Device	p.79
Rotary Joint	p.79
Booster	p.80
PVC or Steel Cables	p.81

Layout a

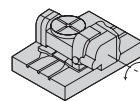

Layout b

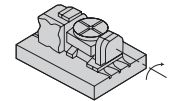

The dimensions above are for tables with a FANUC servo motor. Other motors available (dimensions may increase).

Clamping Block and Bolt

Dimensions = mm

	Type	Q'ty	Layout	T-Slot Width	A	B	C	D	E	F	G	H	I	J	K	L	M
THNC-251	I	4	a b	18	25	12	80	12	33	35	22	21	11	65	40	28	16
THNC-301	II	4	a b	18	25	15	52	12	15	25	40	21	11	85	40	28	16

Note 1: In the case of layout b, contact us for details about mounting.

Note 2: When using a machine with a T-slot pitch other than the above, use suitable clamping blocks and bolts that are available on the market, or order custom-made ones from KOMA (opt.)

Type I

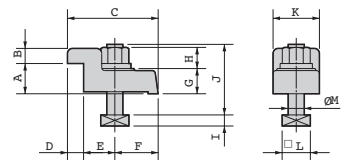

Type II

